



# A.J. Manufacturing, Inc.

1217 Oak Street Bloomer, WI 54724 (715) 568-2204 FAX (715) 568-3099

## PZ-10 (POSITIVE) / VT-10 (NEGATIVE) PRESSURE RELIEF DOORS

### APPLICATION

The PZ-10 (Positive) and the VT-10 (Negative) pressure relief doors are designed to open automatically 1" w.g. (.25kPa) above normal operating system pressure. The function of these doors is to prevent ductwork from imploding or exploding in the event dampers close while the fan is still operating. By opening outward (PZ-10) or inward (VT-10) at a specified pressure setting, the doors permit rapid neutralization of the pressure differential between the inside and outside of the HVAC system. The pressure relief setting is factory set and tested prior to shipment. The pressure setting of the door can be factory adjusted from 1" w.g. to 12" w.g. (.25 kPa to 3 kPa) in 1" w.g. (.25 kPa) increments.

### CONSTRUCTION

#### FRAME

.062" (1.57mm) thick aluminum extrusion, Z & T-Shape.

#### DOOR

.050" (1.27mm) thick aluminum extruded perimeter w/ 24 to 16 ga. (.7 to 1.5 mm) skin and polyurethane filled sealed core (NFPA 90A compliant).

#### TRIM FLANGE

1" (25mm) around entire perimeter.

#### SEAL

Co-extruded PVC Leaf Gasket.

#### RANGE OF SETTINGS

Factory adjusted pressure settings range from 2" w.g. to 12" w.g. (.25 kPa to 3 kPa). Door is specifically set 1" w.g. (.25 kPa) above normal operating system pressure, unless otherwise specified.

#### CABLE ASSEMBLY W/SPRING

Cable assembly limits door opening to 80°, preventing door and duct damage.

#### LATCH

Adjustable magnet assembly is factory set at desired relief pressure. Pressure must be given at time of order to properly place latch. Latch is field adjustable.

#### SERVICE TEMPERATURE

-40°F (-40°C) to 120°F (49°C)

#### DOOR SIZES:

10" W X 10" H (254mm X 254mm)  
12" W X 12" H (305mm X 305mm)  
18" W X 18" H (457mm X 457mm)  
24" W X 24" H (610mm X 610mm)

Width and height dimensions are undersized 3/16 in. (4.7mm).

### PZ-10 (Positive)

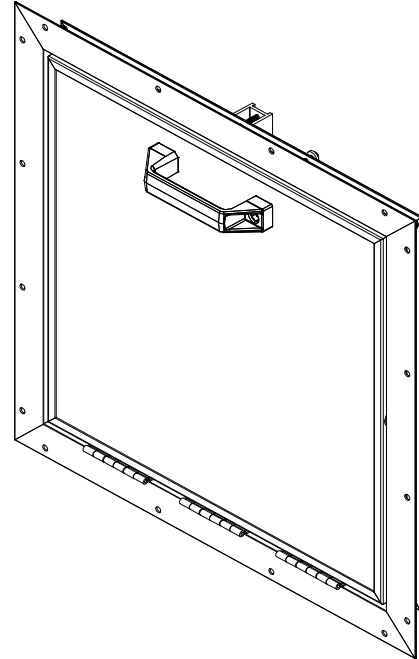

### VT-10 (Negative)

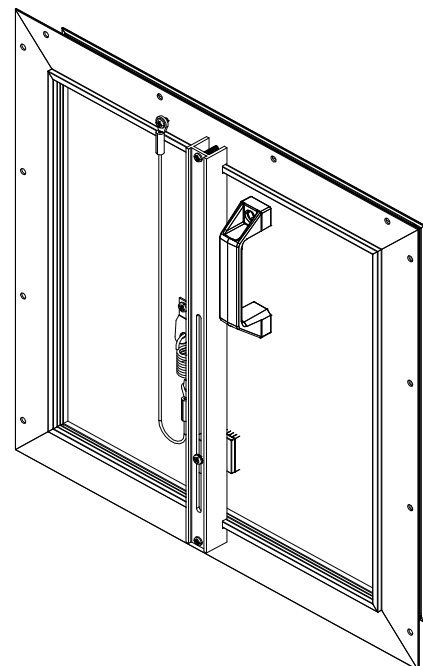

## PRESSURE RELIEF DOORS SELECTION AND PERFORMANCE DATA

### Selection

1. Locate the fan curve for the system (fig. A).
2. Determine the maximum pressure the ductwork is designed to handle. Locate where the maximum pressure of the ductwork intersects the fan curve (fig. A).
3. The figure from step 2 gives the volume of air that should be relieved.
4. Refer to the Relief Airflow vs. Static Pressure chart (fig. B)
5. Select an appropriate door size (standard 18" x 18" [457mm x 457mm]). Determine the volume of air the door will relieve at the maximum design pressure.
6. Divide step 2 by step 5 to determine the number of doors required.
7. Select the set point ranging from 1" w.g. to 12" w.g. (.25 kPa to 3 kPa). The set point is usually 1" w.g. (.25 kPa) above normal operating pressure.

**Figure A  
Fan Curve**

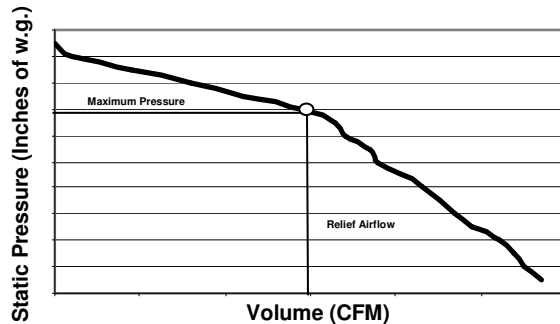

\*\*Note: Fan curve should be supplied with Manufacturer documentation.

**Door Leakage**

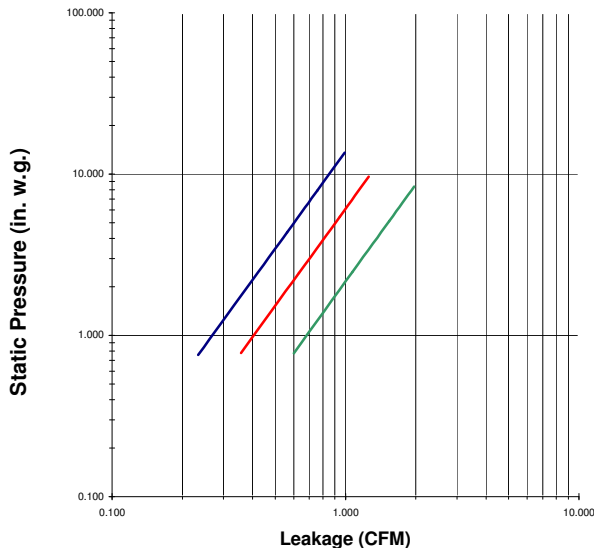

**Figure B**

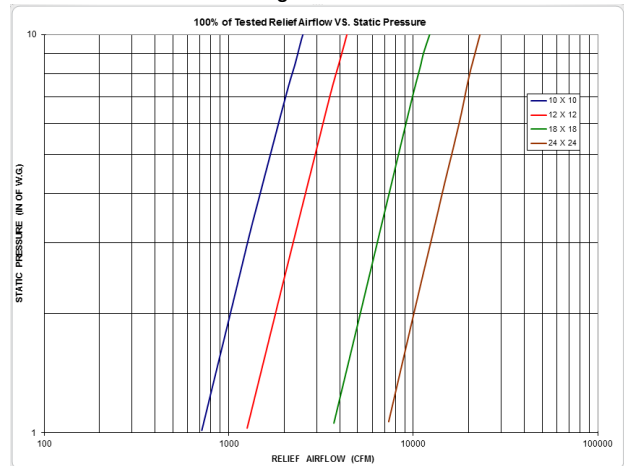

**NOTE:**

1. Door must be installed vertically and level, with hinges down, for proper operation.
2. Desired static pressure settings should be given at the time of order.
3. Consult A.J. MFG. for other applications.
4. Doors must be manually closed after opening due to excess pressure or vacuum.

**Installation:**

Cut door opening to size of door selected. Doors are 3/16" (4.7mm) undersize. Attach door using #10 self-drilling screws.

### PRESSURE RELIEF AND VACUUM RELIEF DOOR SPECIFICATIONS

Furnish and install, at locations shown on plans or in accordance with schedules, pressure relief doors, as manufactured by A.J. Manufacturing, Inc. that meet the following minimum specification. Frames shall be of Z (out swing) or T (in swing) shape, extruded aluminum with minimum wall thickness of .062" (1.57mm). Door panels shall be of solid core, 1 in. (25mm) thick, of extruded aluminum and minimum G60 galvanized steel, injected with closed-cell polyurethane foam. Door gasket shall be of extruded PVC of a leaf-type design, positioned so that the pressure differential of the unit will increase the contact of the gasket against the door. Doors shall open freely at least 70 degrees to afford maximum unobstructed airflow when activated. Door assemblies shall include a spring-cushioned stop device to limit open travel to 80 degrees maximum in order to prevent damage to ductwork and adjacent structures upon pressure relief and system shutdown. Pressure relief settings shall be available from 1" w.g. to 12" w.g. (.25 kPa to 3 kPa) increments. (Designer selects pressure setting.) Pressure relief mechanism shall be factory and field adjustable. Leakage, as tested and certified by an independent laboratory, shall not exceed 0.6 CFM/ft<sup>2</sup> at 12" w.g. (.0003 m<sup>3</sup>/s @ 3 kPa).

**A.J. Manufacturing, Inc.**

1217 Oak Street.  
Bloomer, WI 54724